

BATHSELECT TOUCHLESS COMMERCIAL AUTOMATIC SENSOR FAUCET LIGHT OIL RUBBED BRONZE SPECS

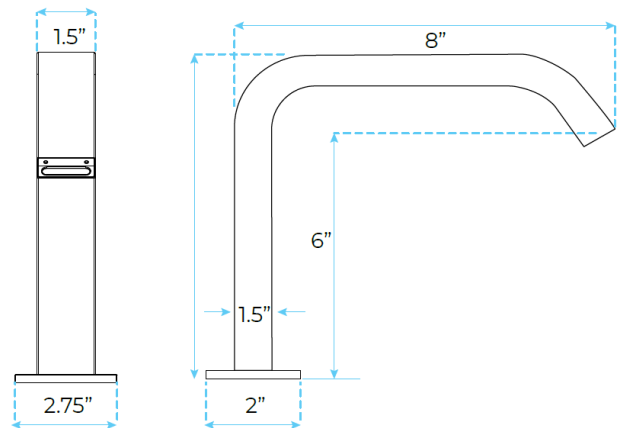

Specs:

- Power: 220-240V OR 4 X 1.5V AA BATTERIES
- Product type: Touchless Tap
- Range: Smooth
- Detection Zone: 16-32 cm or adjustable
- Battery lifespan: 100000 cycles
- Static Power Consumption: 0.36mw
- Working Power consumption: 0.5mw
- Sensing distance: $\leq 50\text{MM}$; $\geq 350\text{MM}$
- Inductive Closing Time: < 2 second
- Dia.of inlet / outlet pipe: G1/2"
- Temperature: 0.1-50°C
- Min. Operating Pressure: 1.0 BAR MP
- Test Range : 0.2-5 Bar



[Visit Product Page](#)